

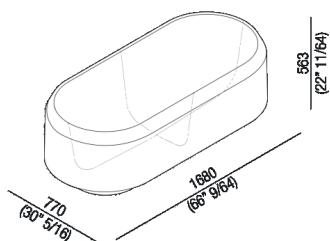

Vasca con parte esterna in marmo  
 AVAS1080Z\_



Patricia Urquiola, 2015

Vasca free-standing compatta in  
 Cristalplant® biobased.



Vasca in Cristalplant® bianco con parte esterna realizzata in marmo bianco di Carrara, nero Marquina o grigio Carnico. Tutte le versioni sono dotate di foro per troppo pieno e sono senza fori per rubinetteria; questa puo' essere collocata a parete o a terra. Completa di piletta sifonata con calotta in Cristalplant® bianco .MET0725C (utilizzabile anche per vasche in esposizione).&#10;

**Finiture**

-  Bianco di Carrara
-  Nero Marquina
-  Grigio Carnico

**Materiali**

-  Marmo

Altezza:	56.3 cm	22" 11/64 inches
Lunghezza:	168 cm	66" 9/64 inches
Peso:	110 kg	243 lbs
Profondità :	77 cm	30" 5/16 inches
Capacita':	320 l	85 gal
Confezione:	100 x 200 x 82 cm	39" 3/8 x 78" 3/4 x 32" 1/4 inches
Peso della confezione:	150 kg	331 lbs

Note: La versione con esterno in marmo puo' essere fornita anche in pietre o marmi a richiesta del cliente con costo da preventivare. Per un'installazione piu' agevole, si suggerisce l'utilizzo del pozzetto per vasca AKITPZVAS.



**Main dimensions**

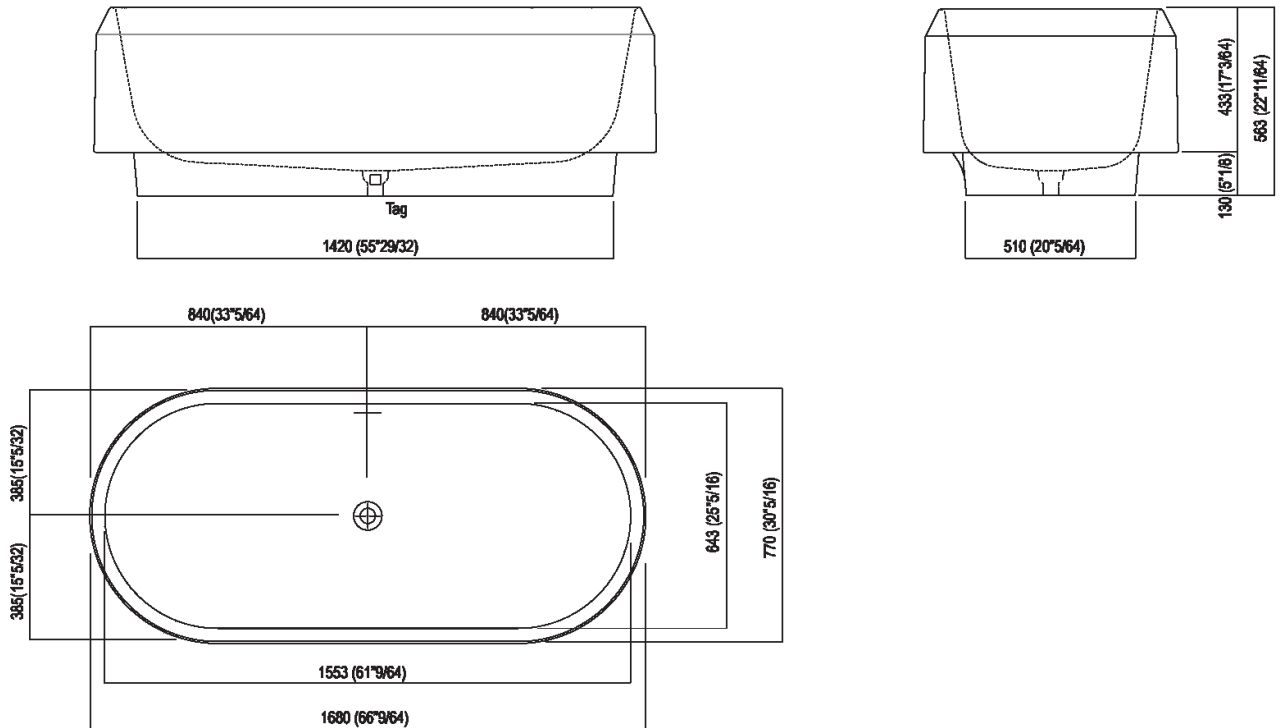





Quote per rubinetteria a parete

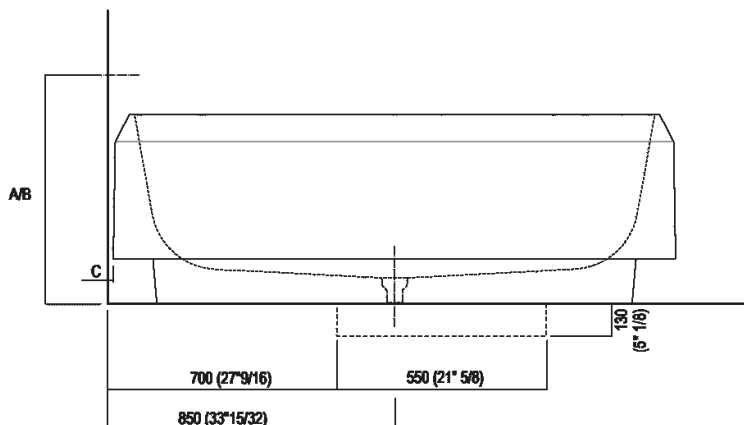
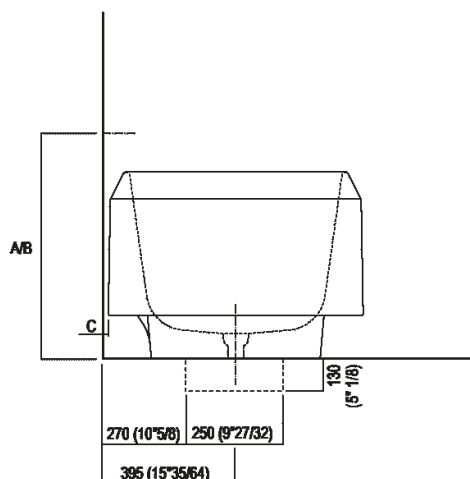

	A*	B**	C
FEZ 2 (EFEZ027)	713 (28 5/64)	-	80 (3 5/32)
LIMÓN (ELIM443)	713 (28 5/64)	-	80 (3 5/32)
MEMORY (EMEM324, EMEM343)	713 (28 5/64)	-	80 (3 5/32)
(EMEM342)	713 (28 5/64)	-	50 (1 31/32)
MEMORY MIX (EMIX437)	713 (28 5/64)	-	50 (1 31/32)
SQUARE (ERUB1117)	-	713 (28 5/64)	50 (1 31/32)
SQUARE (ERUB1118)	-	713 (28 5/64)	80 (3 5/32)
SEN (ESEN0912V)	-	713 (28 5/64)	50 (1 31/32)

\* inserasse gruppo / axial distance for tap  
 \*\* filo inferiore gruppo / Tap's lower edge



Quote per piantane da terra

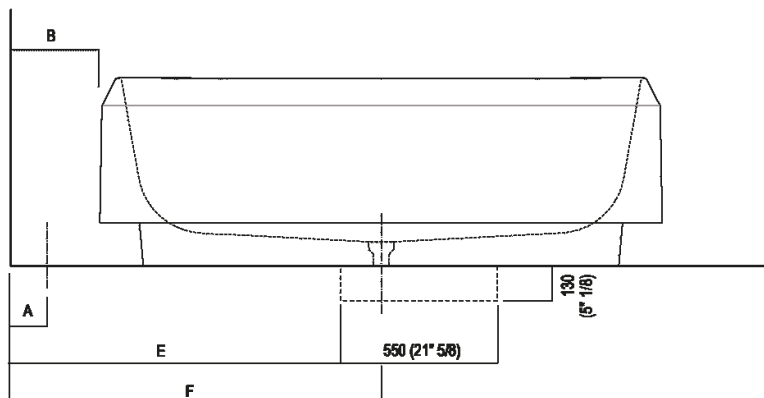
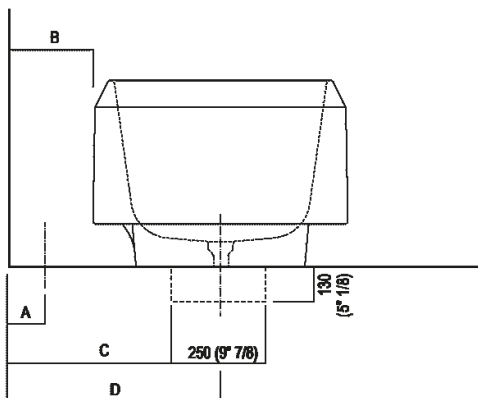

	A	B	C	D	E	F
FEZ 2 (EFEZ026, MET885) (EFEZ028)	90 (3*35/64) 135 (5*5/16)	170 (6*11/16) 210 (8*17/64)	430 (16*59/64) 470 (18*1/2)	555 (21*27/32) 595 (23*27/64)	735 (28*15/16) 775 (30*33/64)	1010 (39*49/64) 1050 (41*11/32)
LIMÓN (ELIM425)	135 (5*5/16)	210 (8*17/64)	470 (18*1/2)	595 (23*27/64)	775 (30*33/64)	1050 (41*11/32)
MEMORY (EMEM325)	135 (5*5/16)	210 (8*17/64)	470 (18*1/2)	595 (23*27/64)	775 (30*33/64)	1050 (41*11/32)
MEMORY MIX (EMIX425)	135 (5*5/16)	210 (8*17/64)	470 (18*1/2)	595 (23*27/64)	775 (30*33/64)	1050 (41*11/32)
LIMÓN / MEMORY / MEMORY MIX (EMEM327)	90 (3*35/64)	170 (6*11/16)	430 (16*59/64)	555 (21*27/32)	735 (28*15/16)	1010 (39*49/64)
SQUARE (ERUB1112, ERUB1115)	90 (3*35/64)	170 (6*11/16)	430 (16*59/64)	555 (21*27/32)	735 (28*15/16)	1010 (39*49/64)
SEN (ESEN0911, ESEN0977)	90 (3*35/64)	130 (5*1/8)	390 (15*23/64)	515 (20*9/32)	695 (27*23/64)	970 (38*3/16)



Note

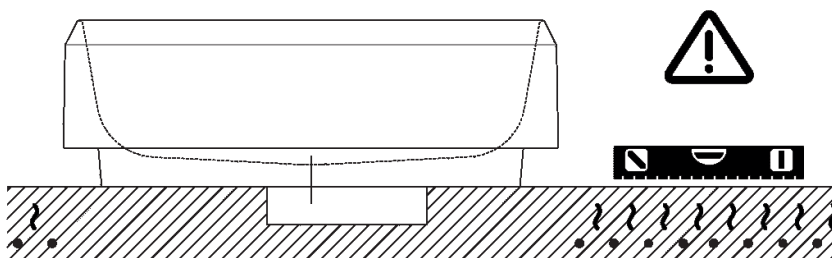

**La vasca deve essere installata su un pavimento perfettamente piano.  
The bathtub must be positioned on a flat floor surface.**

**E' necessario predisporre a pavimento un pozzetto.  
It is necessary to prepare a recess in the floor.**

**Evitare di realizzare impianti di riscaldamento nell'area sottostante la vasca.  
Avoid the installation of floor heating plants in the area under the bathtub.**